

SERIES 48M PRODUCT CODING TABLE
48M-1, 2, 5, 6

48M - X		X		X		X		X		
SWITCH SERIES	SWITCH DESCRIPTION	HOUSING MAT'L CODE	HOUSING MATERIAL	ILLUM. CODE	ILLUMINATION	LED CODE	LED COLOR	LED VOLTAGE CODE	LED VOLTAGE	
48M-1	MECHANICAL, MOMENTARY, SOLDER TERM	1	STAINLESS STEEL	0	NON - LIT	N	NO LED	- (BLANK)	SEE NOTE 1.	
48M-2	MECHANICAL, MAINTAINED, SOLDER TERM	2	ZINC ALLOY CHROME PLATE	1	CENTER SPOT	G	GREEN	05	5V FORWARD	
48M-5	MECHANICAL, MOMENTARY, PC TERM			2	RING	R	RED			
48M-6	MECHANICAL, MAINTAINED, PC TERM			3	STANDBY/ POWER SYMBOL	A	AMBER			
							B			BLUE
							W			WHITE
						RB	RED/BLUE			
						RG	RED/GREEN			

REVISIONS			
REV.	DESCRIPTION	DATE	APPROVED
C	ADDED PC TERMS. E.C.N. 28387	24 AUG 2010	<i>JR</i>
D	REV TO COINCIDE WITH ITW EBA REV 3. E.C.N. 28472	11 MAY 2012	<i>JR</i>
E	ADDED MMs, BI-COLOR, WIRES. E.C.N. 28485	22 AUG 2012	<i>JR</i>

MECHANICAL CHARACTERISTICS:

- SWITCH CIRCUITRY: SPST-NO-DB (FORM X)
- BUTTON TRAVEL (NOMINAL): [2.29] .090
- OPERATING FORCE (NOMINAL): [3 N or 306 g] 10.8 oz
- CONTACT BOUNCE (NOMINAL): 1 ms
- PANEL THICKNESS: [0.51 to 3.05] .020 to .120
- CONTACTS: GOLD PLATED
- NUT TORQUE FORCE (MAX): [11.5 kgf/cm] 10 lb/in
- ENVIRONMENTAL SPECIFICATIONS:
- ACTUATOR INGRESS PROTECTION: IP67
- OPERATING TEMPERATURE:
- NON-LIT: [-40°C to +85°C] -40°F to +185°F
- ILLUMINATED: [-25°C to +85°C] -13°F to +185°F

ELECTRICAL SPECIFICATIONS:

- MOMENTARY CURRENT RATING:
- 250 mA @ 12 VDC: 100K CYCLES
- 150 mA @ 28 VDC: 150K CYCLES
- 100 mA @ 48 VDC: 100K CYCLES
- 10 mA @ 12 VDC: 1 MILLION CYCLES
- MAINTAINED (NOMINAL): 50,000 CYCLES
- DIELECTRIC STRENGTH: 1,000VAC
- INSULATION RESISTANCE: 1G OHM
- CONTACT RESISTANCE (INITIAL): 50m OHMS MAX

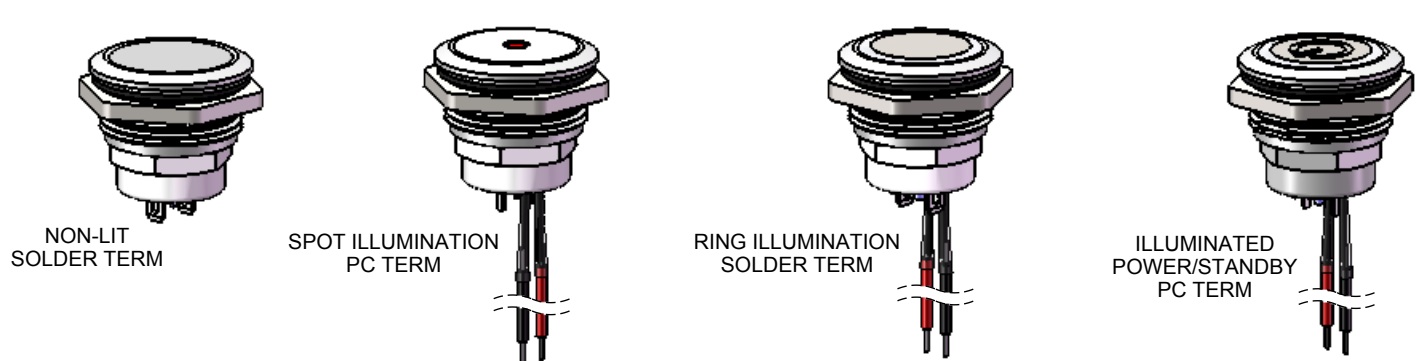
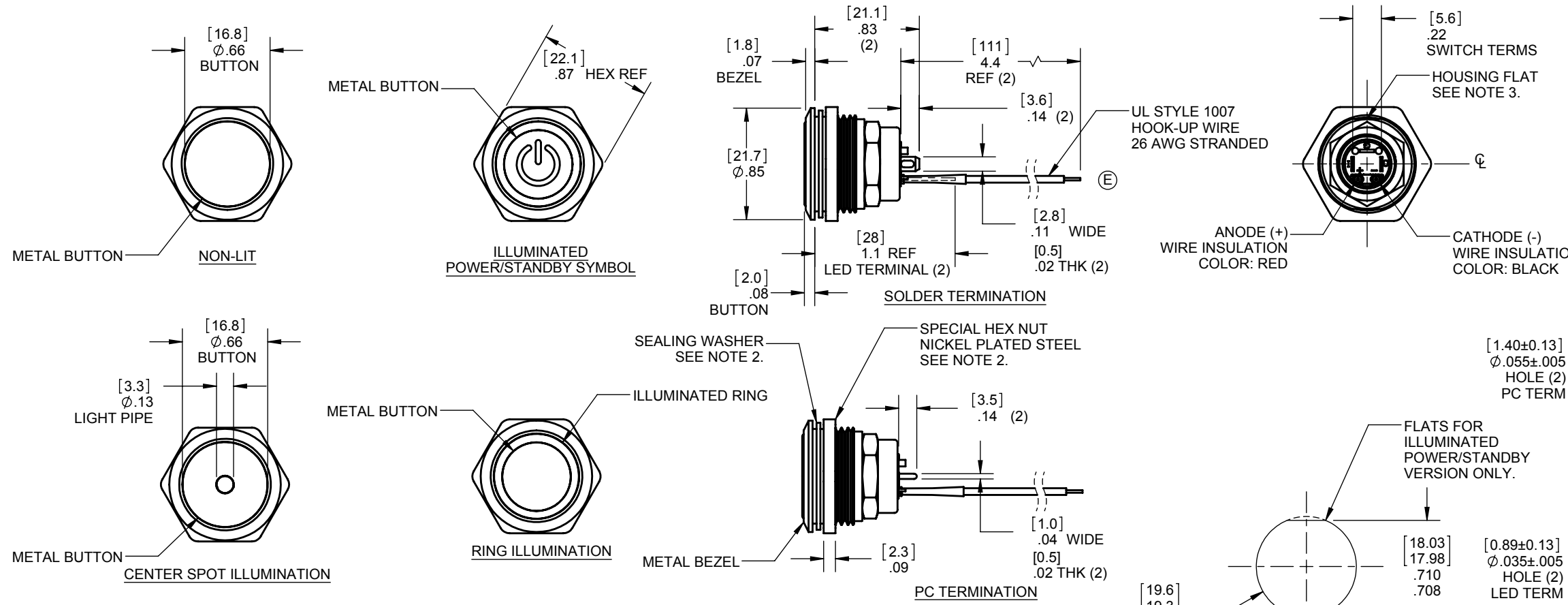

DIMENSIONS ARE IN [MILLIMETERS] INCHES. (E)
TOLERANCES:
3 PLACE DECIMAL ± [0.25] .010
2 PLACE DECIMAL ± [0.5] .02
ANGULAR ± 1/2°

ITW Switches
AN ILLINOIS TOOL WORKS COMPANY

DWG TITLE: **SERIES 48M PUSHBUTTON SWITCH**

RoHS COMPLIANT	DATE	REF:	CODE IDENT.	SIZE B	DWG NO.	REV E
YES	24 AUGUST 2010	EBA 48M Rev 3	No. 04426		48M-1, 2, 5, 6	
✓	<i>JR</i>	<i>SB</i>	<i>SB</i>	SCALE 1:1	SHEET 1 OF 1	