

Interlink Electronics FSR® Force Sensing Resistors®

USB MicroModule
Integration Guide



Table of Contents

1.0	Introduction.....	1
2.0	Scope.....	1
3.0	Theory of Operation	2
4.0	Features and Operation	4
4.1	Using the Pressure-Sensing Actuator	4
4.2	Clicking and Dragging	4
5.0	Mounting.....	5
5.1	Suggested Panel Cut-out	5
5.2	Mounting MicroModule	6
5.3	Supporting MicroModule's PCB	7
5.4	Sealing MicroModule with Silicone Sealant.....	7
6.0	Connection	8
6.1	Molex Header/Mating Connector Specifications	8
6.2	USB Interface Connections	9
6.3	Cable Options.....	10
7.0	USB Information	11
7.1	Device PID and VID.....	11
7.2	Data Packet	11
7.3	USB Suspend Mode	11
7.4	Operating Voltage and Current	11
8.0	Drawings and Dimensions.....	12
9.0	Orderable Part Numbers.....	14
10.0	Intellectual Property & Other Legal Matters.....	14
11.0	Contact Interlink Electronics	15

1.0 Introduction

Designed for OEM integration, MicroModule pointing solutions are ideal for computer cursor control in rugged mobile computers, hardened keyboards, navigation systems, machine control panels, and many other computer pointing applications. MicroModule, with its USB interface, can also be easily interfaced to other control applications such as pan and tilt controllers, motion controllers, CNC controllers and medical control equipment.

MicroModule incorporates Interlink Electronics' VersaPoint® Pressure-Pointing technology. Directional control is achieved by applying pressure in the direction of desired movement. Speed is controlled by altering the amount of applied pressure. The result is smooth cursor movement in any direction, from a precise crawl to a screen-crossing zip. VersaPoint technology has no moving parts to break or wear out, thus delivering reliable, trouble-free cursor control.

The purpose of this document is to guide users through the successful integration of the Interlink Electronics USB MicroModule.

2.0 Scope

This Integration Guide provides the OEM integrator with all of the necessary technical information to successfully integrate the Interlink Electronics USB MicroModule into products such as:

- NEMA-rated industrial pointing devices
- Industrial keyboards
- Military computers
- Motion control applications

Part numbers are detailed in section 9.

3.0 Theory of Operation

The most basic FSR consists of two membranes separated by a thin air gap. The air gap is maintained by a spacer around the edges and by the rigidity of the two membranes. One of the membranes has two sets of fingers which are interdigitated and electrically distinct; each set connects to one trace on the tail. The other membrane is coated with FSR ink. When the two layers are pressed together, the FSR ink shorts the two traces together with a resistance that depends on applied force.

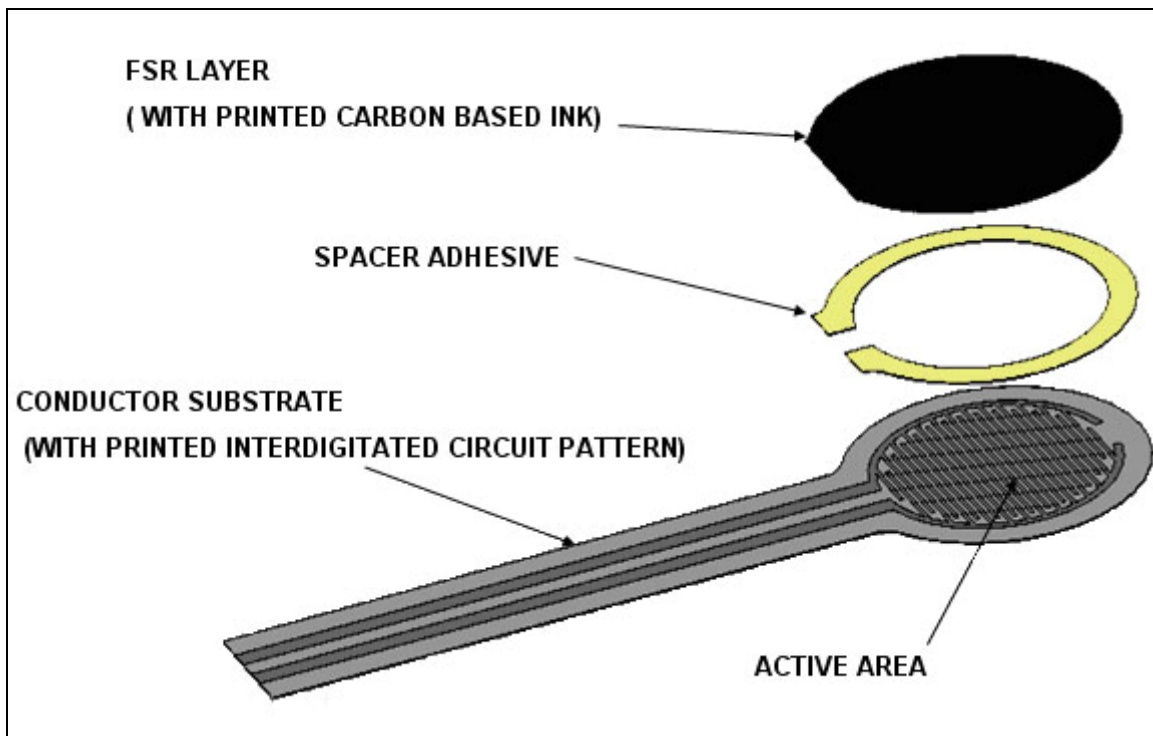

Figure 1: Exploded view of a standard single-zone FSR

The 4-zone FSR used in MicroModule is simply a combination of four basic FSRs arranged in a North, South, East, West pattern. Each zone interpenetrates into the two zones on either side of it. This overlapping of the zones allows us to determine how much force is in each zone relative to the others. Once the relative force in each zone is known, the direction and speed of the mouse pointer can be determined.

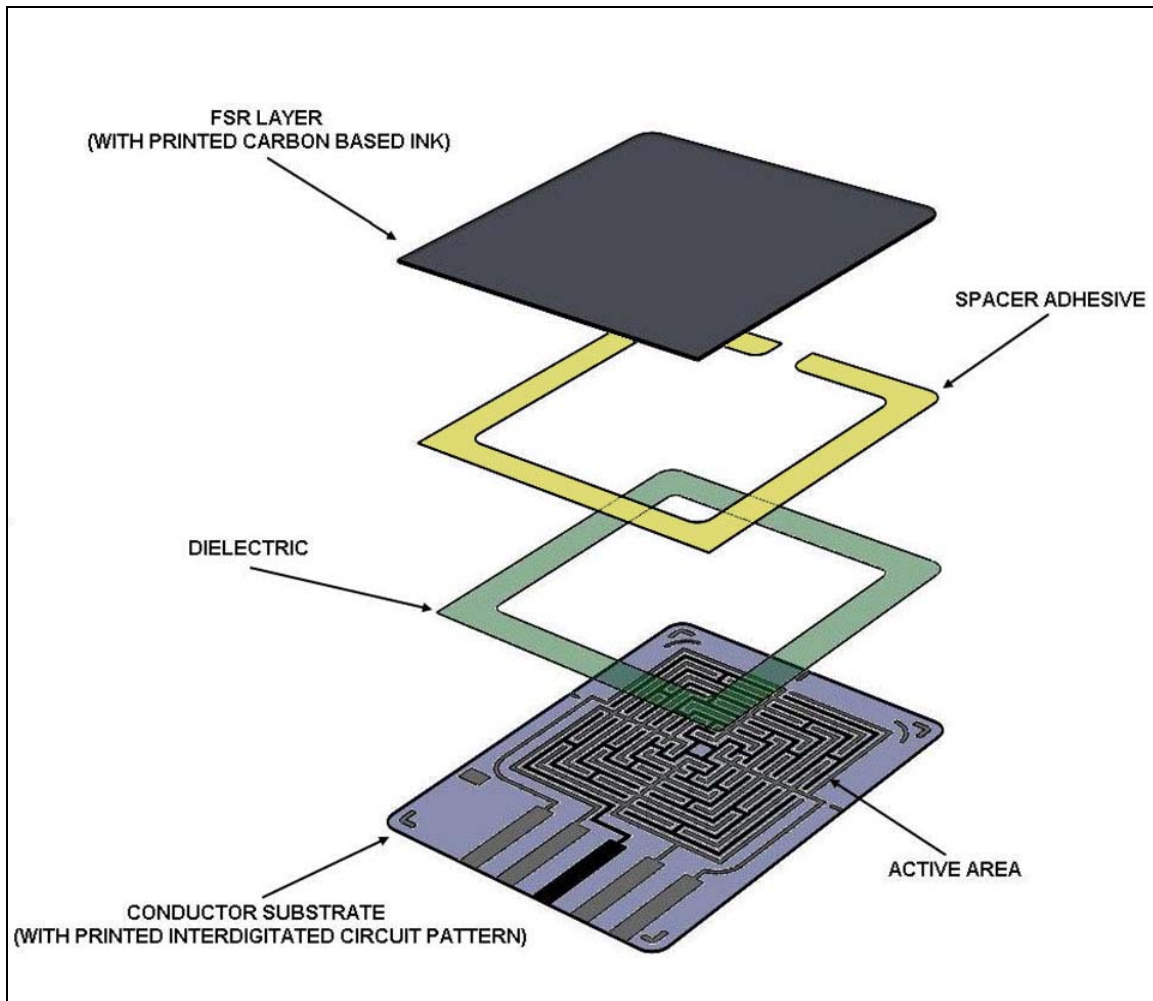

Figure 2: Exploded view of 4-zone FSR

4.0 Features and Operation

4.1 Using the Pressure-Sensing Actuator

MicroModule is available with a choice of two actuator styles, either a Finger Disk or a Mini Joystick (See Figure 3). The Finger Disk actuator is round with a fingertip-shaped divot. The Mini Joystick is a compact control stick. Both actuator styles deliver simultaneous 360-degree control of direction and speed with the touch of a finger. All MicroModule pointing solutions are maintenance free and deliver “mouse” lifetimes in excess of five million actuations.

Either actuator will convert the touch of a finger into smooth cursor movement. To use MicroModule, place your fingertip on the center of the actuator and rock it in the direction you want to move. You can move in any direction — MicroModule has full 360-degree directional control. Use a light touch for precision movement, or increase your pressure to increase the speed of the cursor.

4.2 Clicking and Dragging

The click buttons are located on either side of the actuator and operate like those on a conventional mouse. The left button on the MicroModule is equivalent to the left mouse button and is used as the default primary button. The right button is equivalent to the right mouse button and is used as the default secondary button. You can interchange the operation of the buttons in the Windows Control Panel, if desired (e.g., for left-handed users).

To drag an item, simply press and hold the primary button while moving the cursor with the actuator. Release the primary button to complete the drag operation. Some users find it easier to swap click buttons and use the right click as the primary button, allowing fore-finger cursor control with middle-finger clicking.



Figure 3: Exploded MicroModule Actuator Types (Left: Finger Disk, Right: MiniJoystick)

5.0 Mounting

MicroModule requires less than 10 mm of mounting depth (much less than trackballs or joysticks), allowing it to be easily integrated into tight, cramped spaces. MicroModule's slim mounting profile and small front-panel mounting area frees valuable space for other system components. MicroModule is unaffected by mounting orientation: it can be mounted horizontally, as in a desktop keyboard; vertically, as on a machine control panel; or any angle in between. This gives system designers maximum flexibility with product design and ergonomics.

MicroModule is designed to be blind-mounted into a variety of panel types. Additionally, custom bezels can be fabricated or molded to allow integration into devices such as machine control panels or notebook computers. A detailed 3D CAD model of Interlink's suggested mounting method and geometry can be found on our website at www.interlinkelectronics.com/Support.

5.1 Suggested Panel Cut-out

When mounting MicroModule, the suggested clearance for the cut-out around the actuator (Finger Disk or Mini Joystick) is 0.5 millimeters and 1.0 millimeter for the click buttons. See Figure 4 for details on the suggested cut-out.

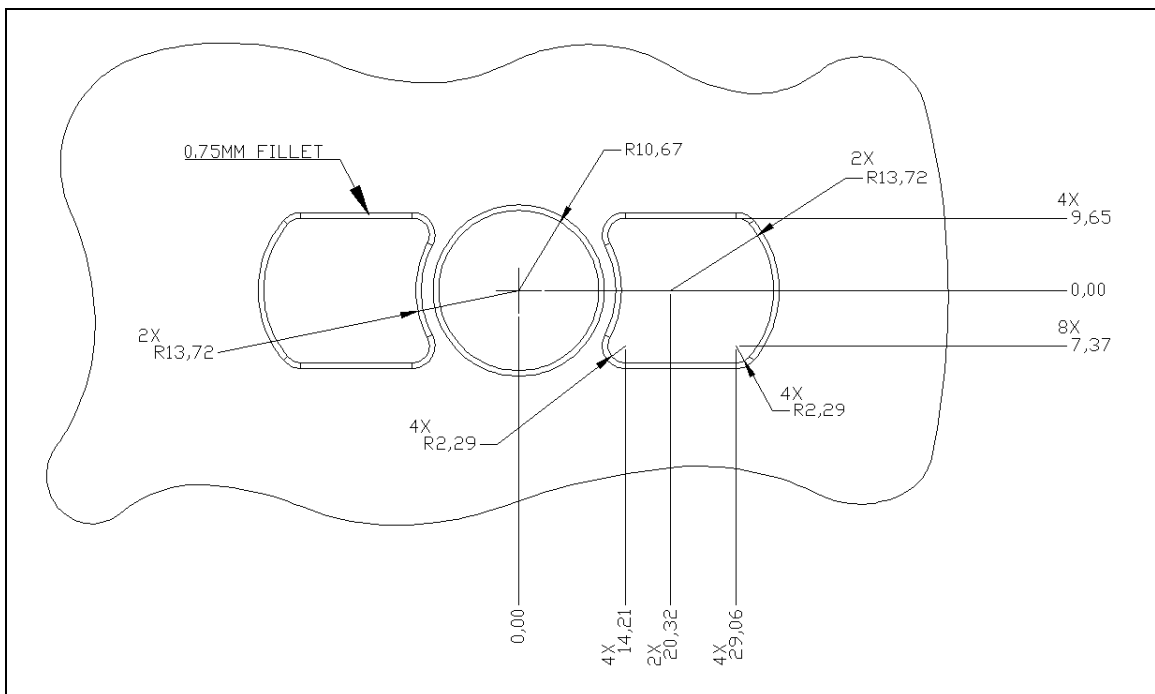

Figure 4: Suggested panel cut-out dimensions. All dimensions are in mm and Reference.

5.2 Mounting MicroModule

To panel mount the module without sealing, fabricate a panel designed with the necessary cut-outs for the actuator and click buttons, and four or more fasteners (e.g., PEM studs, edge clips, hole clips, heat stakes, etc.). When installing, MicroModule should be seated evenly and the fasteners tightened evenly to avoid stressing the printed circuit board. Over torque on the bolts should be avoided; this could crack the PCB and cause the module to fail. It is recommended to use a PCB support bracket to apply even clamping pressure to the MicroModule unit. With proper seating and tightening, a liquid and particulate resistant interface can be created.

Note: The FSR is connected to the PCBA with Z-axis adhesive. This is an electrical, not mechanical bond. A mechanical means of applying a compressive force to the joint should be incorporated in the mounting of the MicroModule. This will prevent the delamination of the adhesive, which can lead to an open circuit. If you follow the Interlink recommended cut-out and PCB support bracket technique, the rubber keypad and the panel edge will be used to apply pressure to the joint (See Figure 5).

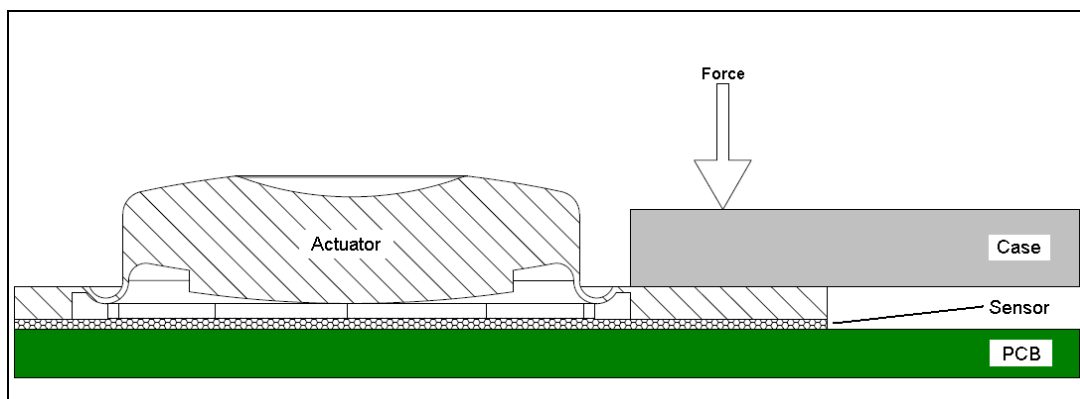

Figure 5: Cross section view showing constant pressure being applied to the sensor contacts by the module's case (panel) through an extension of the rubber keypad actuator

5.3 Supporting MicroModule's PCB

A mounting bracket/clip should be added during installation of MicroModule to support its PCB. The mounting bracket/clip should be designed to mount around the edge of the PCB and should help prevent excessive flex in the PCB. The below figure illustrates the concept of the supporting bracket design.

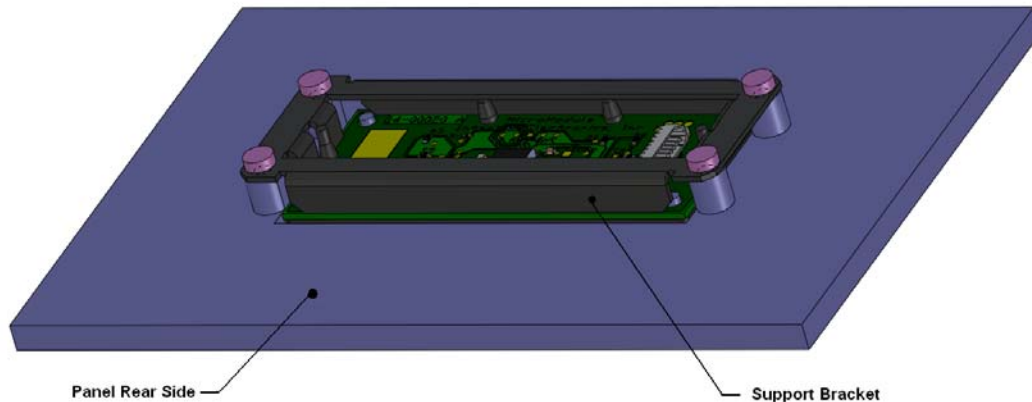

Figure 6: MicroModule Mounting with PCB support bracket. Rear side view of panel/case.

5.4 Sealing MicroModule with Silicone Sealant

MicroModule's silicone-rubber actuators are designed with an integrated sealing rib that allows MicroModule to be sealed into a system during installation. Common silicone sealant or mounting brackets can also be used to create a watertight seal. Once sealed into a system, spills, rain, or humidity will not affect MicroModule's performance--making it ideal for field service, outdoor, or hose-down environments.

RTV silicone sealant can be used as a sealing material. Before starting installation, be sure to clean the panel and rubber keypad thoroughly with isopropyl alcohol. Integrators may also find that some panel/bezel materials will need to be primed with a silicone primer to obtain proper adhesion. To seal MicroModule with silicone sealant, apply a thin bead of sealant to the top of the rubber keypad on the outer edge of the keypad's sealing rib. Minimize the amount of sealant applied to prevent lumping near the active buttons, which could adversely affect the MicroModule's performance. Alternately, sealant can be applied around the perimeter of the module and the bolt holes after it has been mounted into the bezel or panel. For the best possible seal, apply the sealant to both the top of the keypad before installation, and around the perimeter of the module after installation.

6.0 Connection

Connection to MicroModule is accomplished via header J2 (Molex series #53261-0871), where J2 provides the connection to the unit's USB interface (See Table 1 for header pin-out). The integrator will need a cable with one female end (Molex series #51021) to mate to J2 and a second end to mate to their desired interface (e.g., a USB port, PCBA, etc.). Information on the mating connector to MicroModule's PCB header is given below for system integrators to fabricate cables.

6.1 Molex Header/Mating Connector Specifications

The J2 header is a Molex series #53261-0871. Molex connector series #51021 is designed to mate with this header. The metallic contacts that slip into the #51021 housing can be either 50079-8 or 50058-8. The 50079 contacts accept wires AWG 26-28, and the 50058 contacts accept wires AWG 28-32.

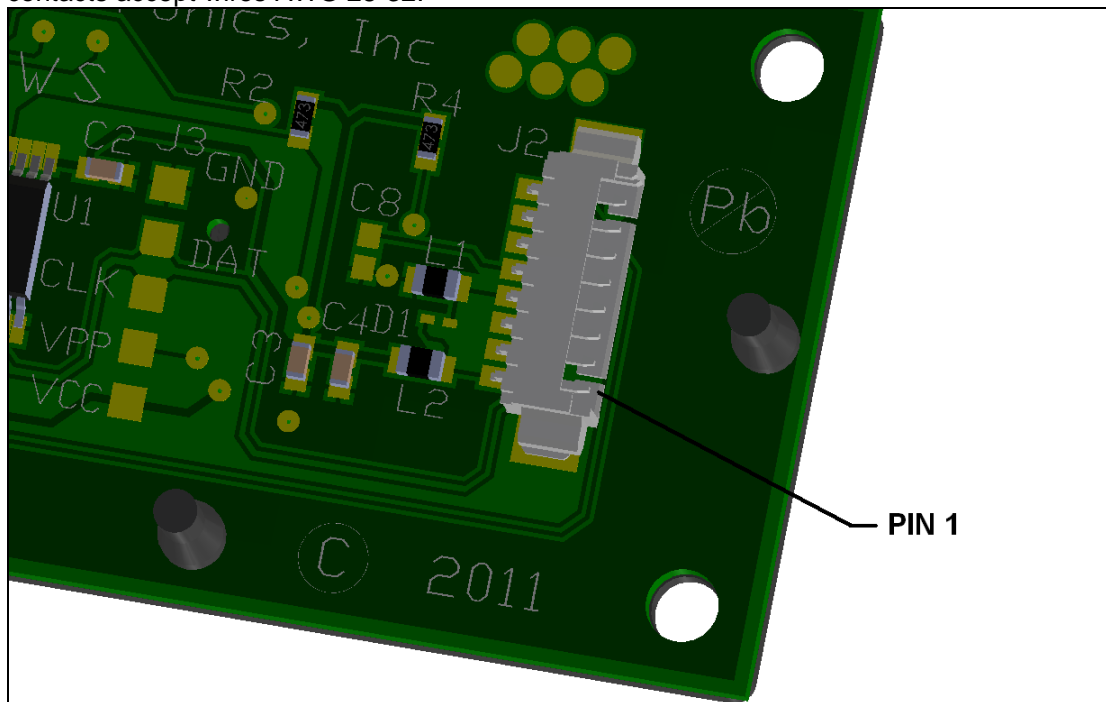

Figure 7: MicroModule Connector (Molex Series 53261).

6.2 USB Interface Connections

The following table shows the pin-out for USB connection to the J2 header. J2 is the 8-pin, 1.25 millimeter-center header on the back of the USB MicroModule's circuit board.

J2 Pin	Signal	Signal Description
1	VCC	+5v
2	D+	D+
3	D-	D-
4	GND	Ground
5	--	--
6	--	--
7	--	--
8	--	--

Table 1: USB connector pin-out

6.3 Cable Options

The following illustrations show the standard Interlink cable options.

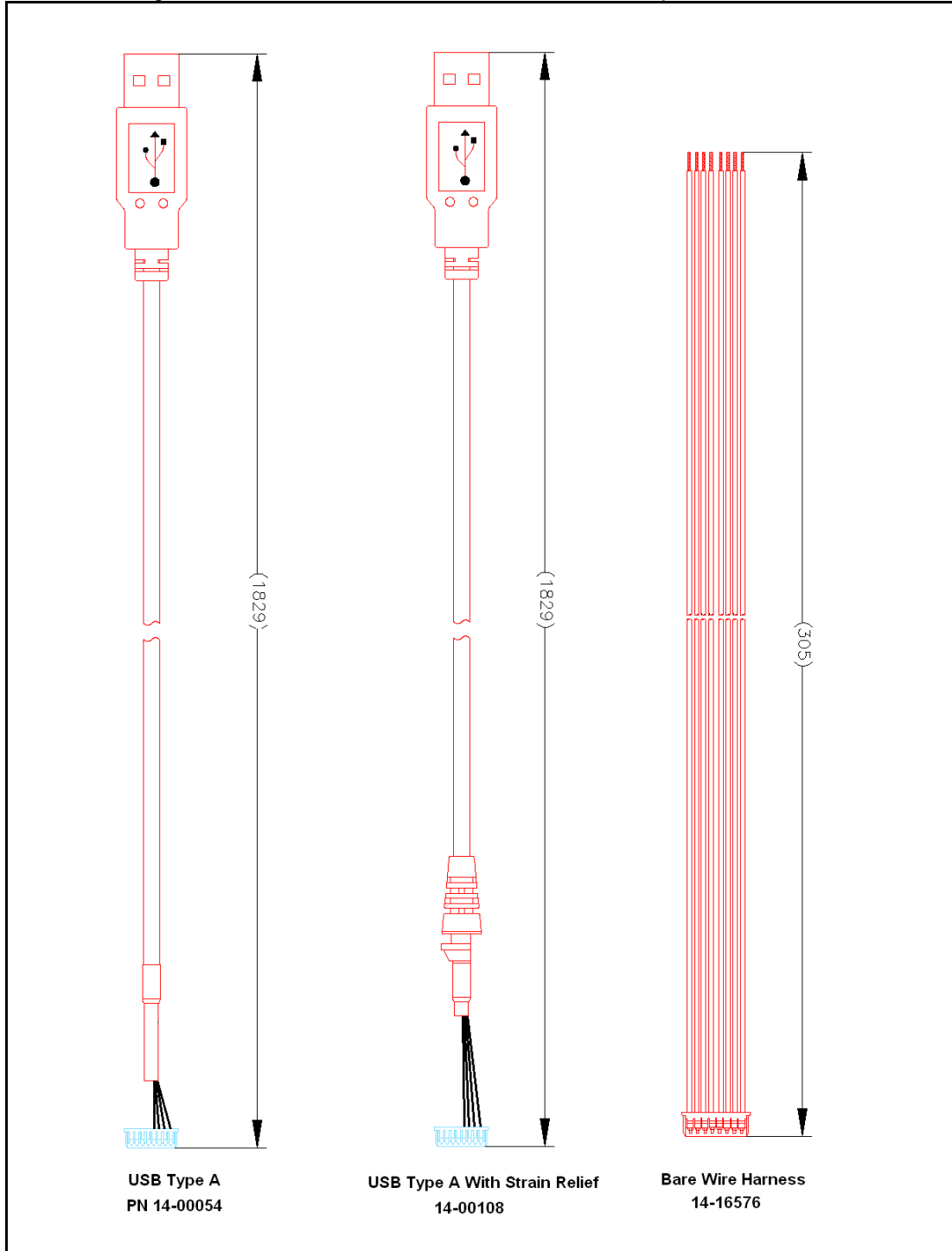

7.0 USB Information

Communication from the host to the microprocessor is done via USB and:

- Uses the low speed USB standard
- Is compatible with any USB 1.1 or 2.0 host
- Enumerates as a HID device
- Uses the standard Windows mouse driver

The microprocessor reports data to the host at a rate of 50 reports/sec.

7.1 Device PID and VID

- This IC's Product ID (PID): 0x0002
- Interlink's Vendor ID (VID): 0x214A

7.2 Data Packet

The data packet from the chip is organized as:

- Byte 0
 - Bit 0 is the Left Button status
 - Bit 1 is the Right Button status
 - Bit 2 is the Middle button status
- Byte 1 reports the X direction. The values range from -127 to +127 counts.
- Byte 2 reports the Y direction. The values range from -127 to +127 counts.

7.3 USB Suspend Mode

The chip will respond to a "suspend" command from the host by going into a low-power sleep mode. In sleep mode, the chip consumes approximately 300 μ A. MicroModule will not wake the host from suspend mode.

7.4 Operating Voltage and Current

The USB VersaPad is bus powered; therefore, it operates at 5V. Under normal operation, the device draws between 10mA to 12mA. This current draw is typical of a full assembly (chip, sensor, etc).

8.0 Drawings and Dimensions

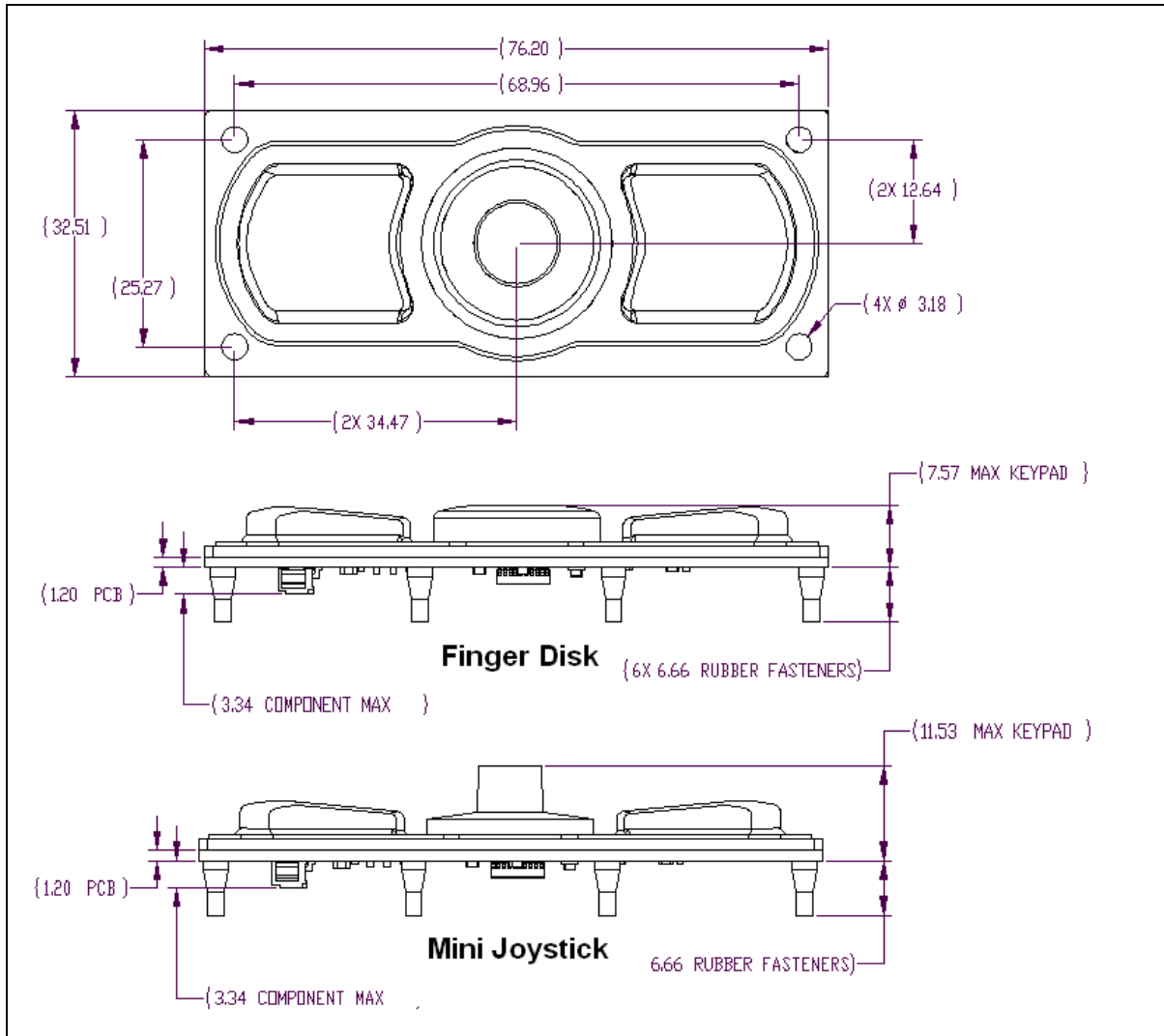

Figure 9: MicroModule Dimension (Reference)

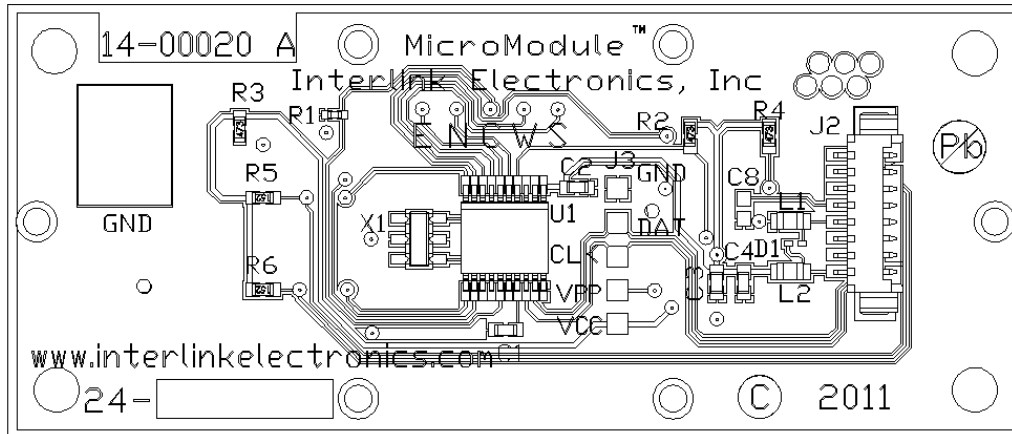

Figure 10: MicroModule Rear View (PCB)

Note: A detailed 3D CAD model of Interlink's MicroModule geometry can be found on our website at www.interlinkelectronics.com/Support.

9.0 Orderable Part Numbers

- **Hardware Development Kit MicroModule USB (54-00028)**
 - QTY 1 MicroModule Demo (Black Button) with USB Cable
 - QTY 1 MicroModule USB, w/MiniJoystick
 - QTY 1 Gray Button Keypad
 - QTY 1 Cable, Harness, 12 inch
 - QTY 1 USB Cable Assembly
 - QTY 1 USB Flash Drive with Product Literature
 - MicroModule USB Datasheet
 - MicroModule USB Integration Guide
- **MicroModule USB, w/Black Button (54-00002)**
- **MicroModule USB, w/Gray Button (54-00023)**
- **MicroModule USB, w/MiniJoystick (54-00011)**
- **MicroModule USB, w/ Black Button FL-SI Keypad (54-00046)**
- **Cable, Harness, 12 inch (14-16576)**
- **USB Cable Assembly (14-00054)**
- **USB Cable Assembly with Strain Relief, Demo (14-00108)**

10.0 Intellectual Property & Other Legal Matters

Interlink Electronics holds several domestic and international patents for its Force Sensing Resistor technology. FSR and Force Sensing Resistor are company trademarks. All other trademarks are the property of their respective owners.

The product information contained in this document provides general information and guidelines only and must not be used as an implied contract with Interlink Electronics. Acknowledging our policy of continual product development, we reserve the right to change, without notice, any detail in this publication. Since Interlink Electronics has no control over the conditions and method of use of our products, we suggest that any potential user confirm their suitability for their own application.

11.0 Contact Interlink Electronics

United States

Corporate Office

Interlink Electronics, Inc.

546 Flynn Road

Camarillo, CA 93012, USA

Phone: +1-805-484-8855

Fax: +1-805-484-9457

Web: www.interlinkelectronics.com

Sales and support: sales@interlinkelectronics.com

Japan

Japan Sales Office

Kannai-Keihin Bldg. 10F/1004

2-4-2 Ougi-cyo, Naka-ku

Yokohama-shi, Kanagawa-ken 231-0027

Japan

Phone: +81-45-263-6500

Fax: +81-45-263-6501

Web: www.interlinkelec.co.jp